



**Kince**  
Automation

健時自動化設備有限公司

选择性波峰焊方案





**Kinco**  
Automation

## 聯繫方式

- 公司 :
- 呈送 :
- 备份 :
- 传真 :
- 来自 :
- 备份 : 健时@黎總
- 136 0252 9092
- 传真 : 076985323019
- 日期 : 2017-9-12



# 設備外觀

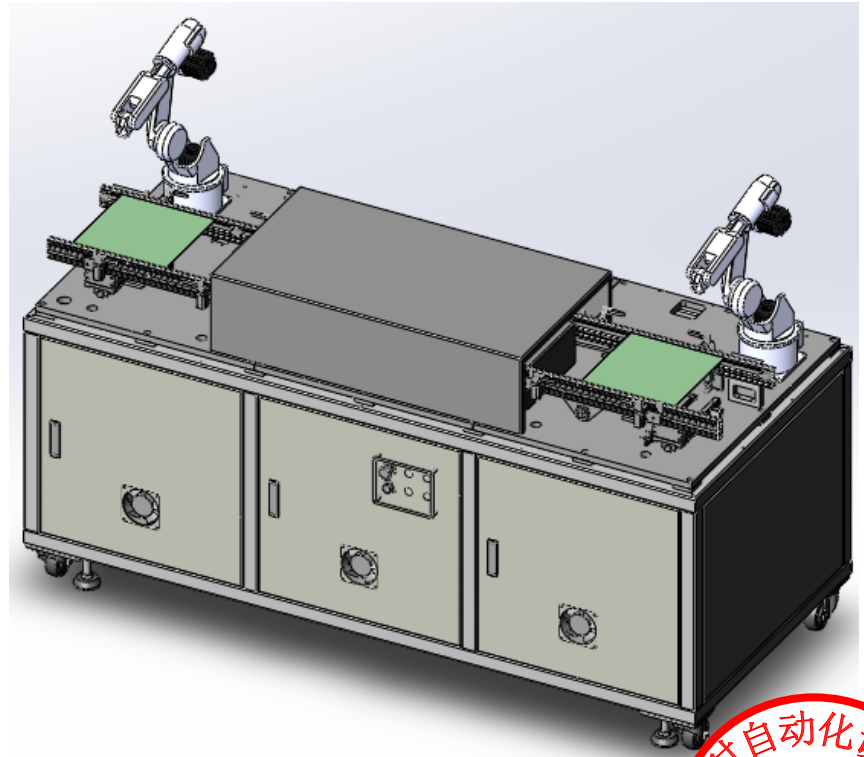
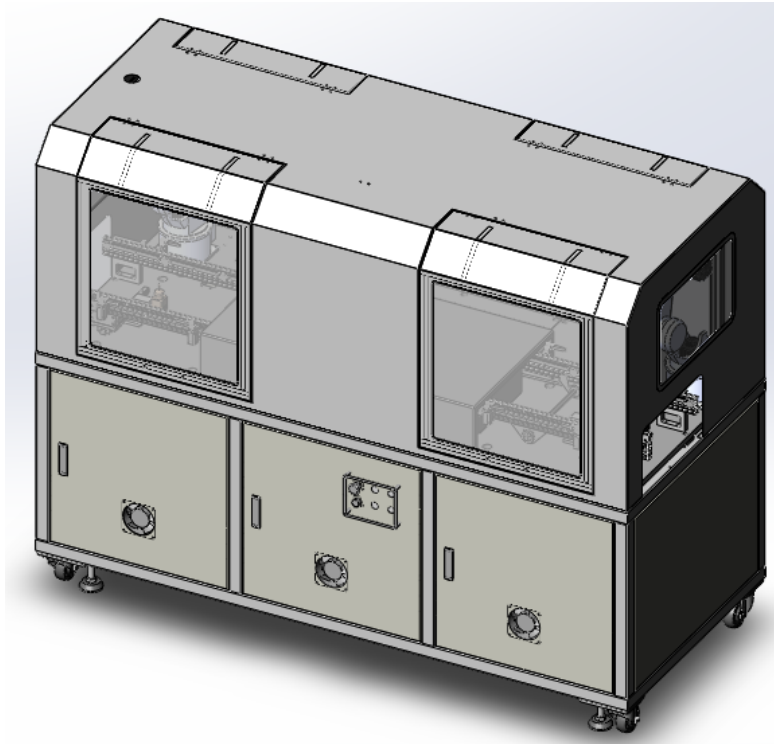



**Kinco**  
Automation

# 設備簡述1

6轴  
关节机械手

产品

加温区

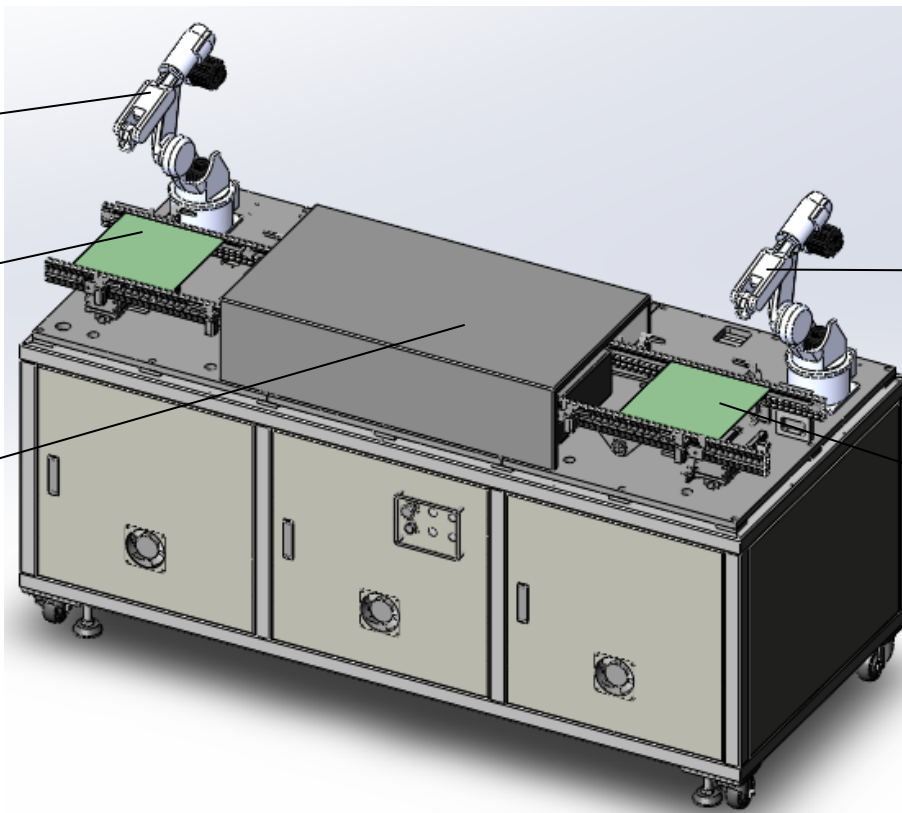

6轴  
关节机械手

产品



# 設備簡述2

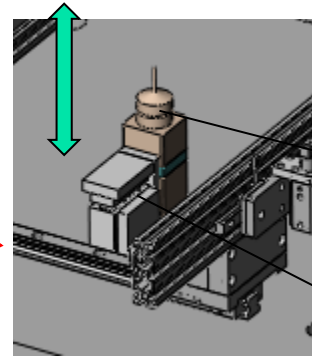
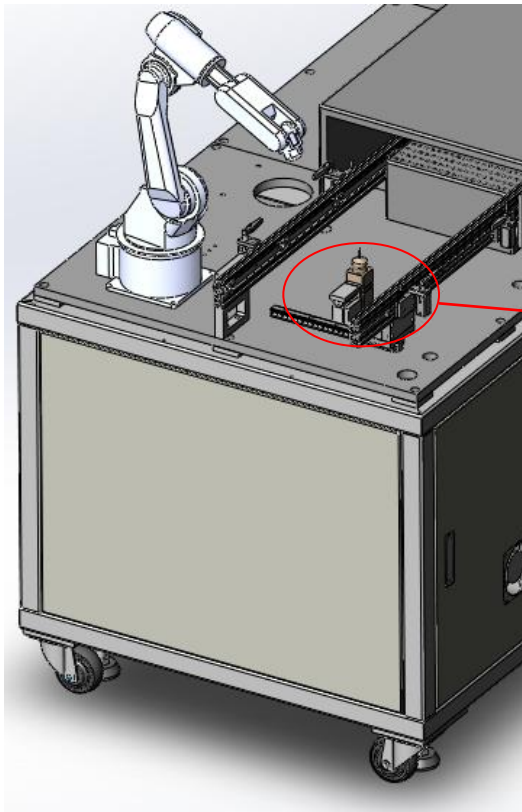

喷射阀

气缸





**Kinco**  
Automation

# 設備簡述3

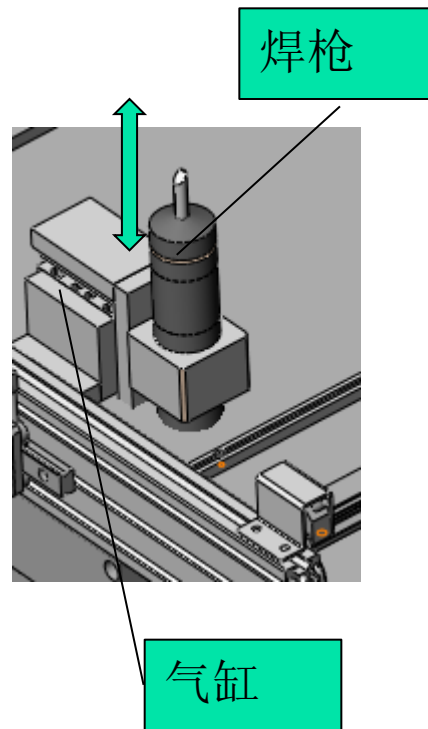
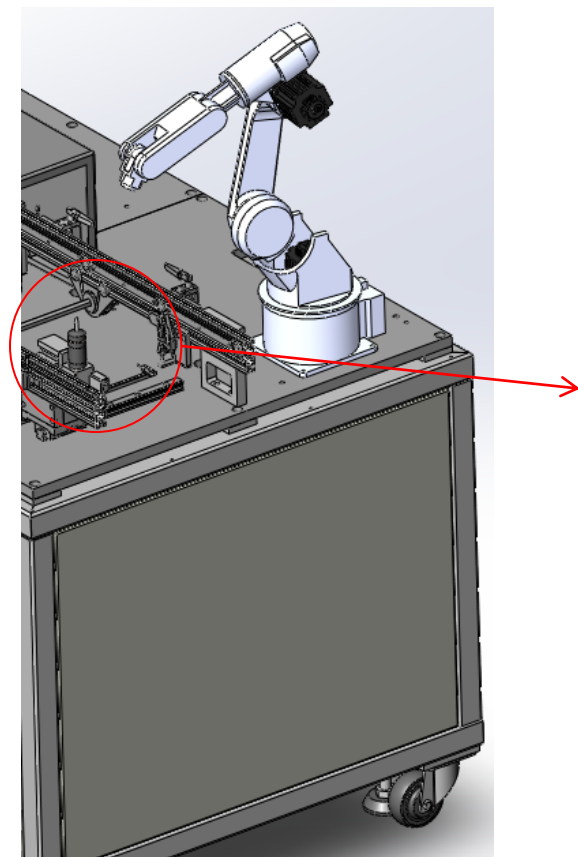



# 設備規格

---

祝：商祺

